



Type 8750 can be combined with...



System ELEMENT

Valve system

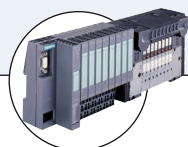

Type 8644

Valve island



MFC 8712

Mass Flow Controller



Type 8400

Temperature sensor

Flow Rate Controller, flow control system for gases

- Reliable and robust system
- Reduced interfaces
- Orifice plate and actuator in one
- Easy operation
- Fit for stand-alone operation

The flow rate controller, Type 8750, is a system to measure and control gases using the differential pressure principle. The reliable and robust system consists of an ELEMENT continuous control valve, Type 2301, with the compact process controller Type 8693 and two pressure transmitters, Type 8323. These components are supplied within an assembled system including a special body.

The Bürkert flow rate controller does not need a separate flow meter. The control valve serves as orifice plate. From the pressure difference across the valve and the given density and temperature a nominal flow can be calculated. Therefore the flow characteristics of the valve are given to the process controller. The volume flow can then be adjusted by changing the stroke of the control valve. So all components of the control loop build an integrated system.

The flow rate controller offers a high repeatability and large measuring range. With the combination of orifice plate and control valve the pressure drop is reduced in comparison to conventional solutions. With the variable orifice of the control valve the measurement range is increased. Low assembly costs and easy commissioning are further advantages of this unique system.

Technical Data	
Complete system	
Port size	DN15 to 100
Media	Air, Nitrogen, Carbondioxide, other gases
Media temperature	0 to 80 °C
Ambient temperature	0 to 55 °C
Control media	Instrument air acc. to DIN ISO 8573-1
Supply pressure	5.6 - 7 bar
Pilot air ports	Threaded ports G 1/8 stainless steel
Process connection	Flange connection acc. to DIN EN 1092-1 other connections on request
Process controller	
Power supply	24 V DC ± 10 %
Ripple	10%; no technical direct current
Electrical connection	Power supply: circular connector M12 × 1, 4-pins In/output signal: circular connector M12 × 1, 8-pins / Bus Internal: circular connector M8 × 1, 4-pins
Protection class	IP65 / IP67 acc. to EN 60529
Bus communication	Profibus DPV1, DeviceNet
Pressure transmitter	
Measurement range	0 - 100 mbar to 0 - 16 bar (standard: 0 - 10 bar)
Measurement principle	Piezoresistive
Measurement error	≤ 0.5% of full scale
Materials	
Body	Stainless Steel
Actuator housing	PPS, Stainless Steel
Process controller	PPS, Stainless Steel
Pressure transmitter housing	Stainless Steel
Seal Seat	PTFE, Stainless Steel on request
Packing	PTFE-V-Seals
Sensor body	Stainless steel

FRC Schematic

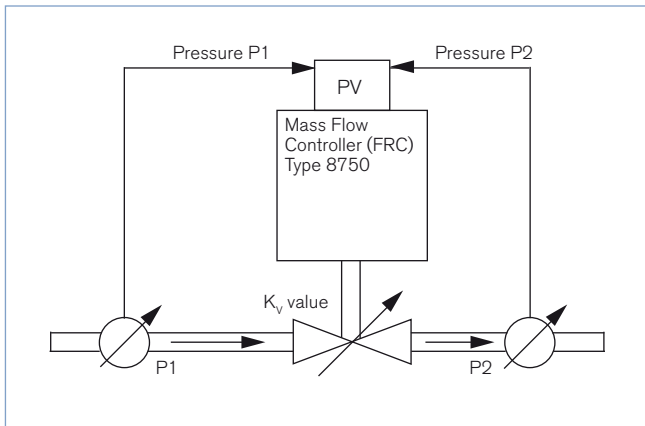

Determination of k_v values

Pressure drop	k_v value for gas [m ³ /h]
Subcritical $p_2 > \frac{p_1}{2}$	$= \frac{Q_N}{514} \sqrt{\frac{T_1 \rho_N}{p_2 \Delta p}}$
Supercritical $p_2 < \frac{p_1}{2}$	$= \frac{Q_N}{257 \rho_1} \sqrt{T_1 \rho_N}$

- k_v Flow coefficient [m³/h]⁶⁾
- Q_N Standard flow rate [m³/h]⁷⁾
- p_1 Inlet pressure [bar]⁸⁾
- p_2 Outlet pressure [bar]⁸⁾
- Δp Differential pressure $p_1 - p_2$ [bar]
- ρ Density [kg/m³]
- ρ_N Standard density [kg/m³]
- T_1 Temperature of medium [(273+t)K]

⁶⁾ measured for water at 20 °C, $\Delta p = 1$ bar, via the device

⁷⁾ Standard conditions at 1.013 bar and 0 °C (273K)

⁸⁾ Absolute pressure

Intake section according to EN ISO 5167 - 1

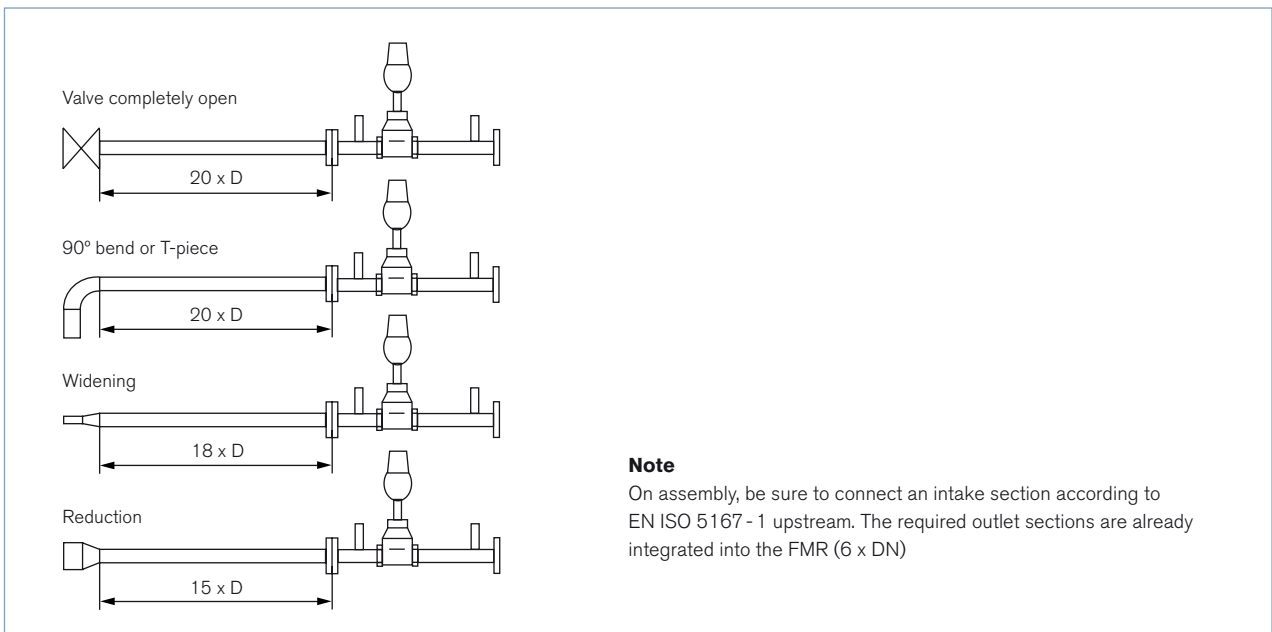

Note

On assembly, be sure to connect an intake section according to EN ISO 5167 - 1 upstream. The required outlet sections are already integrated into the FMR (6 x DN)

For highest precision consider the intake sections according to EN ISO 5167 - 1, the outlet section is integrated in the body .



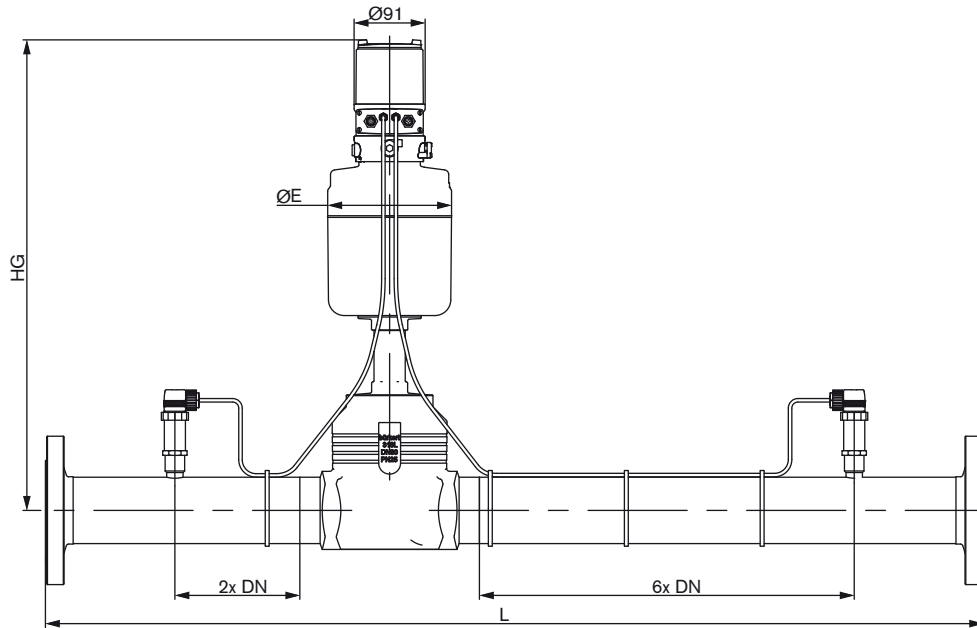



Dimensions [mm]



DN (Port connection) [mm]	Actuator size	L[mm]	HG[mm]	Ø E[mm]
15	Ø70	330	383	91
25	Ø70	500	392	91
40	Ø90	700	478	120
50	Ø130	800	536	159
65	Ø130	1000	590	159
80	Ø130	1200	598	159
100	Ø130	1400	608	159

Ordering chart for valves

Flange acc. to DIN EN 1092 - 1, PTFE seal

Port size [mm]	Seat DN [mm]	Actuator size	K _{vs} value	Pressure range	Air flow rate at p1=6 and p2=3 bar(g)		Article no.
					Q _{max} [Nm ³ /h]	Q _{min} [Nm ³ /h]	
DN15	15	M (70 mm)	4.3	0 - 10 bar	350	20	280436 
DN25	25	M (70 mm)	12.0	0 - 10 bar	900	40	280437 
DN40	40	N (90 mm)	17.5	0 - 10 bar	1300	70	280438 
DN50	50	P (130 mm)	37.0	0 - 10 bar	2900	120	280439 
DN65	65	P (130 mm)	65.0	0 - 10 bar	5500	200	280440 
DN80	80	P (130 mm)	100	0 - 10 bar	8500	350	280441 
DN100	100	P (130 mm)	140	0 - 6 bar	12000	500	280442 

¹⁾ K_{vs} represents the maximum flow capacity of a control valve series. The K_v value [m³/h] is measured to DIN EN 60534 - 2-3 with water (5 - 40 °C) and a pressure drop of 1 bar over the valve.

²⁾ The air flow rates mentioned above are given as a reference. The values refer to air with a temperature of 20 °C. The condition for the min. and max. limits is determined at 10 and 90% positions and turbulent air flow.

Note

Please ask for advice when sizing the flow rate controller FRC. Contact your local sales centre



Further versions on request

- Port connection
- Seat reductions
- Reduced pressure range
- Sealing Steel/Steel
- Communication via Fieldbus

Specification code for Flow Controller Type 8750

Example 8750 - 040.0 - 032.0 - FD26 - EE - A - N - P - AG - S - B

Specifications key

8750 - [] - [] - [] - [] - [] - [] - [] - [] - [] - []

Pipe size [mm] (connection DNA)

15.0
25.0
40.0
50.0
65.0
80.0
100.0

Port connection	Orifice [mm] (DN)		
	Std.	1st Reduction	2nd Reduction
DN15	15.0	10.0	08.0
DN25	25.0	20.0	15.0
DN40	40.0	32.0	25.0
DN50	50.0	40.0	32.0
DN65	65.0	50.0	40.0
DN80	80.0	65.0	50.0
DN100	100.0	80.0	65.0

Port connection	Line connection				
	Flange			Weld end	
[mm]	EN-1092 f-f DIN3202	ANSI ASME B16.5 f-f ISA S75.03	JIS 10K, B2238 f-f JIS B2002 S20	ISO 4200	DIN 11850 S2
DN15	FD22	FA02 ¹⁾	FJ01 ¹⁾	SA42 ¹⁾	SD42 ¹⁾
DN25	FD24	FA04 ¹⁾	FJ03 ¹⁾	SA44 ¹⁾	SD44 ¹⁾
DN40	FD26	FA06 ¹⁾	FJ05 ¹⁾	SA46 ¹⁾	SD46 ¹⁾
DN50	FD27	FA07 ¹⁾	FJ06 ¹⁾	SA47 ¹⁾	SD47 ¹⁾
DN65	FD28	FA08 ¹⁾	FJ07 ¹⁾	SA48 ¹⁾	SD48 ¹⁾
DN80	FD29	FA09 ¹⁾	FJ08 ¹⁾	SA49 ¹⁾	SD49 ¹⁾
DN100	FD30	FA10 ¹⁾	FJ09 ¹⁾	SA39 ¹⁾	SD50 ¹⁾

¹⁾auf Anfrage

Seal material	
SS	steel/steel
EE	PTFE/steel

Control function	
A	spring closed (NC)
B	spring open (NO)

Software feedback	
O	Not specified
F	1 binary input + 1 analogue output + 2 binary outputs

Communication	
O	without (serial interface)
Y	Profibus-DP-V1
D	Device Net

Max. medium pressure (P _{max})		
AA	0-0.100	bar (g)
AB	0-0.160	bar (g)
AC	0-0.250	bar (g)
AD	0-1	bar (g)
AE	0-2.5	bar (g)
AF	0-6	bar (g)
AG	0-10	bar (g)
AH	0-16	bar (g)
AJ	0-25 ¹⁾	bar (g)
V1	0-1	bar (abs)

¹⁾ on request

Sensor types - process values	
P	pressure before and after

Actuator size	
Port connection	
DN15	M (70 mm)
DN25	M (70 mm)
DN40	N (90 mm)
DN50	P (130 mm)
DN65	P (130 mm)
DN80	P (130 mm)
DN100	P (130 mm)

Note

You can fill out the fields directly in the PDF file before printing out the form.

Specification sheet for Type 8750

▶ Please fill out and send to your local Bürkert Sales Centre* with your inquiry or order

Company	Contact person
Customer no.	Department
Address	Tel./Fax
Postcode/Town	E-Mail

= mandatory fields to fill out Quantity Required delivery date

Operating data

Site of control

Measuring and control task

Pipeline DN PN

Pipe material

Process medium

Type of media Gas

Standard density Kg/Nm³

	Min	Standard	Max	Unit
<input checked="" type="checkbox"/> Flow rate (QN [Nm ³ /h]) ²⁾	<input type="text"/>	<input type="text"/>	<input type="text"/>	<input type="text"/>
<input checked="" type="checkbox"/> Temperature at valve inlet T1	<input type="text"/>	<input type="text"/>	<input type="text"/>	<input type="text"/>
<input checked="" type="checkbox"/> Absolute pressure at valve inlet P1	<input type="text"/>	<input type="text"/>	<input type="text"/>	<input type="text"/>
<input checked="" type="checkbox"/> Absolute pressure at valve outlet P2	<input type="text"/>	<input type="text"/>	<input type="text"/>	<input type="text"/>

²⁾ standard unit
Liquid Q = m³/h; Steam W = Kg/h; Gas QN = Nm³/h

Valve features

Standard connection (flange) DIN ANSI JIS other Versions

Seat sealing material Metal PTFE

Function NC³⁾ NO³⁾

Max. sound level accepted dB (A)

Pilot pressure min. max.

³⁾ NC: resting position with spring closed; SFB: resting position with spring open

Controller features

Pressure measurement

<p><input checked="" type="checkbox"/> Communication</p> <p><input type="checkbox"/> Analogue signals for setpoint/output</p> <p><input type="checkbox"/> Input 0/4-20 mA / 0-5/10 V + 1 Binary input</p> <p><input type="checkbox"/> Output 0/4-20 mA / 0-5/10 V + 2 Binary output</p> <p>or</p> <p><input type="checkbox"/> Fieldbus</p> <p><input type="checkbox"/> Profibus DP-V1</p> <p><input type="checkbox"/> Device Net</p>	<p><input checked="" type="checkbox"/> Measuring range</p> <p><input type="checkbox"/> 0 - 100 mbar</p> <p><input type="checkbox"/> 0 - 160 mbar</p> <p><input type="checkbox"/> 0 - 250 mbar</p> <p><input type="checkbox"/> 0 - 1 bar</p> <p><input type="checkbox"/> 0 - 2.5 bar</p> <p><input type="checkbox"/> 0 - 6 bar</p> <p><input type="checkbox"/> 0 - 10 bar</p> <p><input type="checkbox"/> 0 - 16 bar</p> <p><input type="checkbox"/> 0 - 25 bar</p> <p><input type="checkbox"/> 0 - 1 bar (absolute)</p> <p><input type="checkbox"/> other range max. media pressure: <input type="text"/> bar</p>
---	---

*To find your nearest Bürkert facility, click on the orange box → www.burkert.com

In case of special application conditions, please consult for advice.

Subject to alterations
© Christian Bürkert GmbH & Co. KG

1803/9_EU-en_00891925